

ASSEMBLY AND OPERATING INSTRUCTIONS

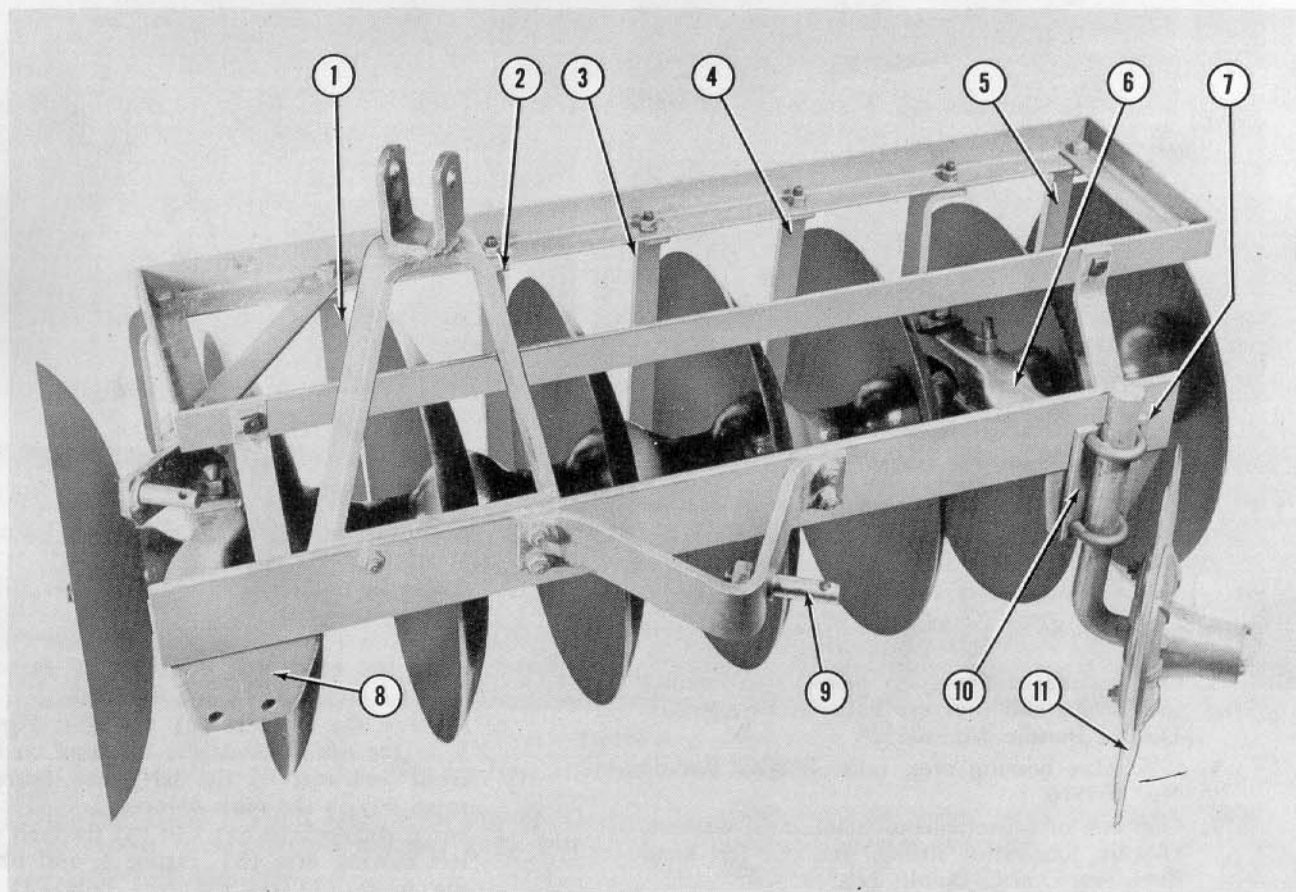

Figure 1

The Dearborn One-Way Plow

The Dearborn One-Way Plow is easily adjusted and operated from the seat of the Ford Tractor and will economically do many soil preparation jobs in addition to plowing.

The plow is a Lift Type implement equipped with eight high grade alloy steel discs, an 18 inch cut out coulter and a rugged 4 x 4 angle steel main frame.

The coulter may be adjusted to absorb side draft and easily penetrates heavy trash and weeds. The 22 inch discs spaced 8 inches apart provide an outstanding combination for faster, better plowing.

The Dearborn One-Way Plow, Model 10-200 is shipped in the following eight bundles. Check the shipment against this list to be sure all parts are received.

DEARBORN MOTORS CORPORATION

BIRMINGHAM, MICHIGAN

www.nrtractorclub.com

ONE-WAY PLOW

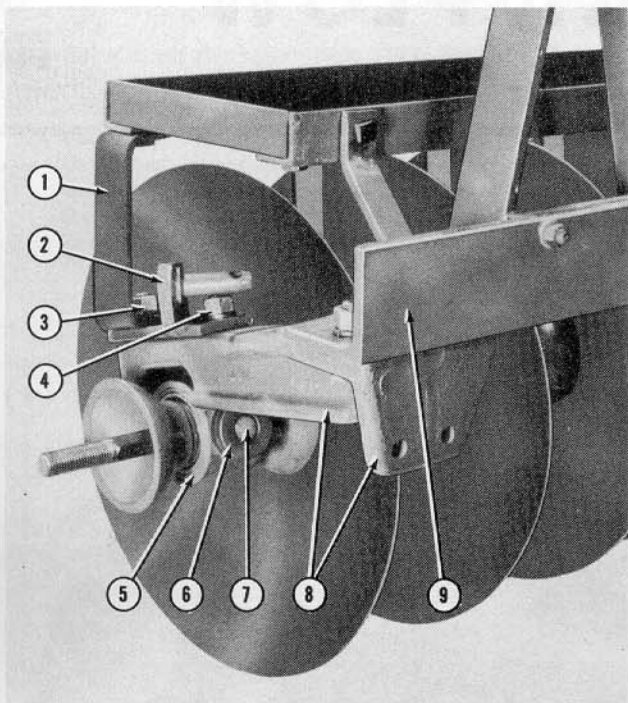

Figure 2

Right Bearing Arm Attached

1. One weight box frame and mounting bracket wired together. D.M.C. Bundle No. 105513.
2. One main frame and "A" frame assembly. D.M.C. Bundle No. 105514.
3. One disc gang assembly. D.M.C. Bundle No. 105519.
4. One bundle of five trash guards, two coulters lock straps and four eye bolts wired together. D.M.C. Bundle No. 105518.
5. & 6. One bearing arm, each. D.M.C. Bundle No. 105516.
7. One box of miscellaneous bolts, nuts, washers, U-bolts, lubrication fittings and one left hand hitch pin. D.M.C. Bundle No. 105520.
8. One coulters stem assembly. D.M.C. Bundle No. 105515.

ASSEMBLY PROCEDURE

NOTE: Assembly of the Dearborn One-Way Plow is the responsibility of the Ford Tractor and Dearborn Farm Equipment dealer. The Plow should be delivered completely assembled. The following instructions are provided in case of need.

1. Position the disc gang as shown in Figure 1, and attach the bearing arms (6) and (8) as follows:
 - a. Position the eyebolts (3) and (4), Figure 2,

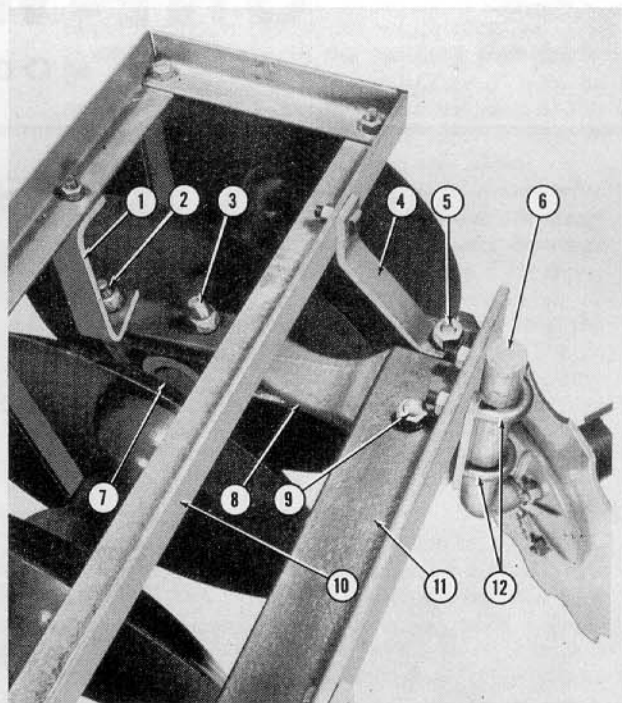

Figure 3

Left Bearing Arm and Coulters Assembly Attached

- a. so the eye (6) fits over the trunnion (7) on the front and rear of the right hand bearing spool (5).
 - b. Insert the eyebolts (3) and (4) through the bearing arm (8), Figure 2, place the hitch pin plate (2) on the bolts as shown and place the brace (1) on the rear eyebolt. Secure with lockwashers and nuts.
 - c. Position the eyebolts (2) and (3), Figure 3, so the eye fits over the trunnion on the front and rear of the left hand bearing spool (7) in the same manner.
 - d. Insert the eyebolts (2) and (3) through the left bearing arm (8), Figure 3, and place the brace (1) on the rear bolt (2) as shown. Secure eyebolts with lockwashers and nuts.
2. Insert one lubrication fitting in the rear trunnion on each bearing spool (5), Figure 2, and (7), Figure 3.
 3. Attach the left bearing arm (8), Figure 3, to the left end of the main frame (11), with the bolts (5) and (9). Place a brace (4) on the bolt (5) and secure bolts (5) and (9) with lockwashers and nuts.
 4. Bolt the right bearing arm (8), Figure 2, to the right end of the main frame (9) with the two bolts (10) and (12), Figure 4. Insert the bolt (12), Figure 4, through the right side of

ONE-WAY PLOW

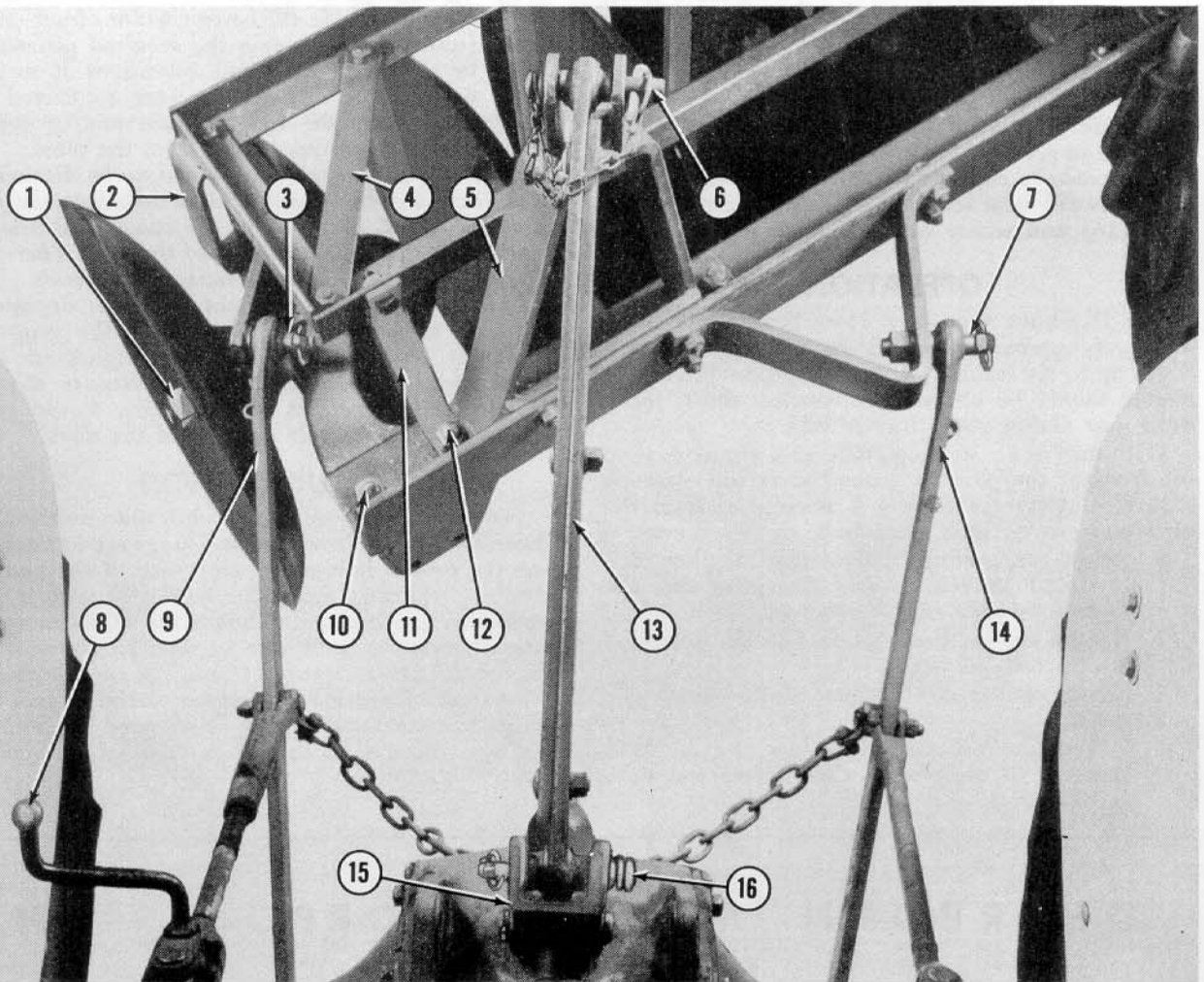

Figure 4

One-Way Plow Attached to the Ford Tractor

- the "A" frame (5) and position the brace (11) as shown. Secure bolts (10) and (12) with lockwashers and nuts.
5. Bolt the left hitch pin (9), Figure 1, in place on the main frame as shown.
6. Attach the coulter (11), Figure 1, to the left end of the main frame (11), Figure 3, with two U-bolts (12). Place the lock straps (7) and (10), Figure 1, on the U-bolts as shown and secure the U-bolts with lockwashers and nuts. Insert a lubrication fitting in the hole provided on the coulter bearing.
7. Bolt the left end of the weight frame (10), Figure 3, to the braces (1) and (4) as shown. Secure with lockwashers and nuts.
8. Bolt the right end of the weight frame to the braces (2) and (11) as shown in Figure 4. Secure with lockwashers and nuts.
9. Attach the cross brace (4), Figure 4, and the trash guards (1), Figure 1, to the weight frame

as shown and secure with the bolts, lockwashers and nuts provided.

10. Attach the trash guards (2), (3), (4) and (5) as shown in Figure 1 and secure with the bolts, lockwashers and nuts provided.

ATTACHING

Tractor rear tires should be weighted with a calcium chloride solution and spaced on 60 inch centers. Front wheel should be set on 56 inch centers. When excess weight is added to the weight frame of the plow, front wheel weights should be used to improve tractor steering and stability.

1. Back tractor into position so the lower links (9) and (14) are aligned with the hitch pins (3) and (7), Figure 4.
2. Slip the left lower link (14), Figure 4, on the hitch pin (7) and secure with a linch pin as shown.

ONE-WAY PLOW

3. Attach the right lower link (9), Figure 4, to the hitch pin (3), using the tractor leveling crank (8) for alignment. Secure with a linch pin.
4. Disconnect the upper link (13), Figure 4, from the tractor and attach it to the "A" frame (5) with the pin (6) and linch pin.
5. From the tractor seat align the forward end of the upper link (13), Figure 4, with the tractor three-hole rocker (15) by moving the tractor forward or backward slightly. Insert the pin (16) and secure with the linch pin provided.

OPERATION

The Dearborn One-Way Plow has an operating width of approximately $4\frac{1}{2}$ ft. and an operating depth up to six inches. Under average conditions the tractor should be operated in constant draft, using third gear and at about four M.P.H.

With the tractor leveling crank (8), Figure 4, raise the front of the plow to ground level and establish a furrow. After the furrow is established level the plow and proceed with the following adjustments.

1. Adjust the leveling crank so that the plow runs level. *At no time should the front disc cut deeper than the rear disc.*
2. Set the coulter blade parallel to the travel of the tractor rear tires.
3. Set the coulter down sufficiently to absorb side draft.
4. In hard ground add weight (not to exceed 150 pounds) to the plow weight frame and raise

the coulter until the desired penetration and side draft control is obtained.

5. When necessary adjust the angle of the coulter blade to obtain the correct width of cut on the front disc. To obtain the required penetration in extremely hard soil conditions it may be necessary to add weight (not to exceed 150 pounds) to the weight frame and/or remove one or more disc blades from the plow.

CAUTION: *In the event it is necessary to disassemble the disc gang, be very careful to note how the gang was assembled. Each end of the spools and bearings are curved to fit the curvature of the discs. Therefore, if improperly assembled breakage may result.*

After the first few hours of operation tighten the nuts on all bolts securely, especially the gang bolt nuts (1), Figure 4. Disc blades are high grade alloy steel and should never be cold rolled to sharpen. A satisfactory method of sharpening would be to grind the back surface or edge of the discs.

LUBRICATION

There are three points for lubrication on the Dearborn One-Way Plow. Grease fittings are located, one on the coulter hub and one on each of the two disc bearings. Fittings should be lubricated with a good grade of gun grease on completion of assembly and daily thereafter. Lubricate until clean grease shows at the end of the bearing. (Seals will not be damaged by excess lubrication). After an extended period of idleness the grease should be changed by pumping in new grease until the old is expelled through the seals.

DEARBORN MOTORS CORPORATION

EQUIPMENT WARRANTY

DEARBORN MOTORS CORPORATION warrants all parts (other than pneumatic tires, inner tubes and batteries) of equipment bearing the trade-mark "Dearborn" to the original purchaser thereof at retail, for a period of six (6) months from the date of delivery thereof to the original purchaser at retail, to be free from defects in workmanship and material under normal use and service. The obligation of Dearborn Motors Corporation under this warranty shall be limited to shipment, without charge to the original purchaser at retail, of the part or parts of such Dearborn Equipment intended to replace the part or parts acknowledged by Dearborn Motors Corporation to be defective in workmanship or material. This warranty is in lieu of all other warranties, expressed or implied, and of all obligations or liabilities on the part of Dearborn Motors Corporation, and it neither assumes nor authorizes any person to assume for it, any other obligation or liability in connection with workmanship or material of equipment bearing the trade-mark "Dearborn" or any part thereof. This warranty shall not apply to any Dearborn Equipment, or any part thereof, which has been damaged in any accident, or by fire, flood, or Act of God, or abused or misused, or which has been altered elsewhere than at the place of manufacture, or in which the original purchaser thereof at retail, has used or allowed to be used, parts not made or supplied by Dearborn Motors Corporation. Dearborn Motors Corporation reserves the right at any time to make changes in the design, materials and/or specifications of equipment bearing the trade-mark "Dearborn" and/or accessories, therefor, without thereby becoming liable to make similar changes in equipment bearing the trade-mark "Dearborn" and/or accessories therefor, previously manufactured.

DEARBORN MOTORS CORPORATION

BIRMINGHAM, MICHIGAN